



Who are we

ABOUT US

Founded in 2012, for 13 years and counting, we have been committed to sustainability, decarbonization, and creating a better tomorrow.

We constantly shoot for excellence in everything we do, which has been proved by our technology and quality with customer satisfaction worldwide.

TECHNICAL SERVICES

Our professional team consistently delivers cost efficiency alongside streamlined after-sale services and maintenance, ensuring the prime levelized cost of energy for every project.

It takes a team effort to ensure large-scale projects go off without a hitch. We have an expert team of R&D, process control management team, and well-experienced sales and after-sale team to guard the whole life circle of your project.

7+

In the TOP 20 list for 7 years and counting.

20+

Equipped with over 20 full-automatic production lines, advanced laser cutting machine and screw pile production lines.

100,000 Tons

Production base is located in Tianjin. Annual production capacity reaches 100,000 tons and in expanding.



CORPORATE HISTORY

Becoming the global model of technological excellence in photovoltaic mounting system industry, so that each and every bit of clean electricity shines with the light of technology and quality.

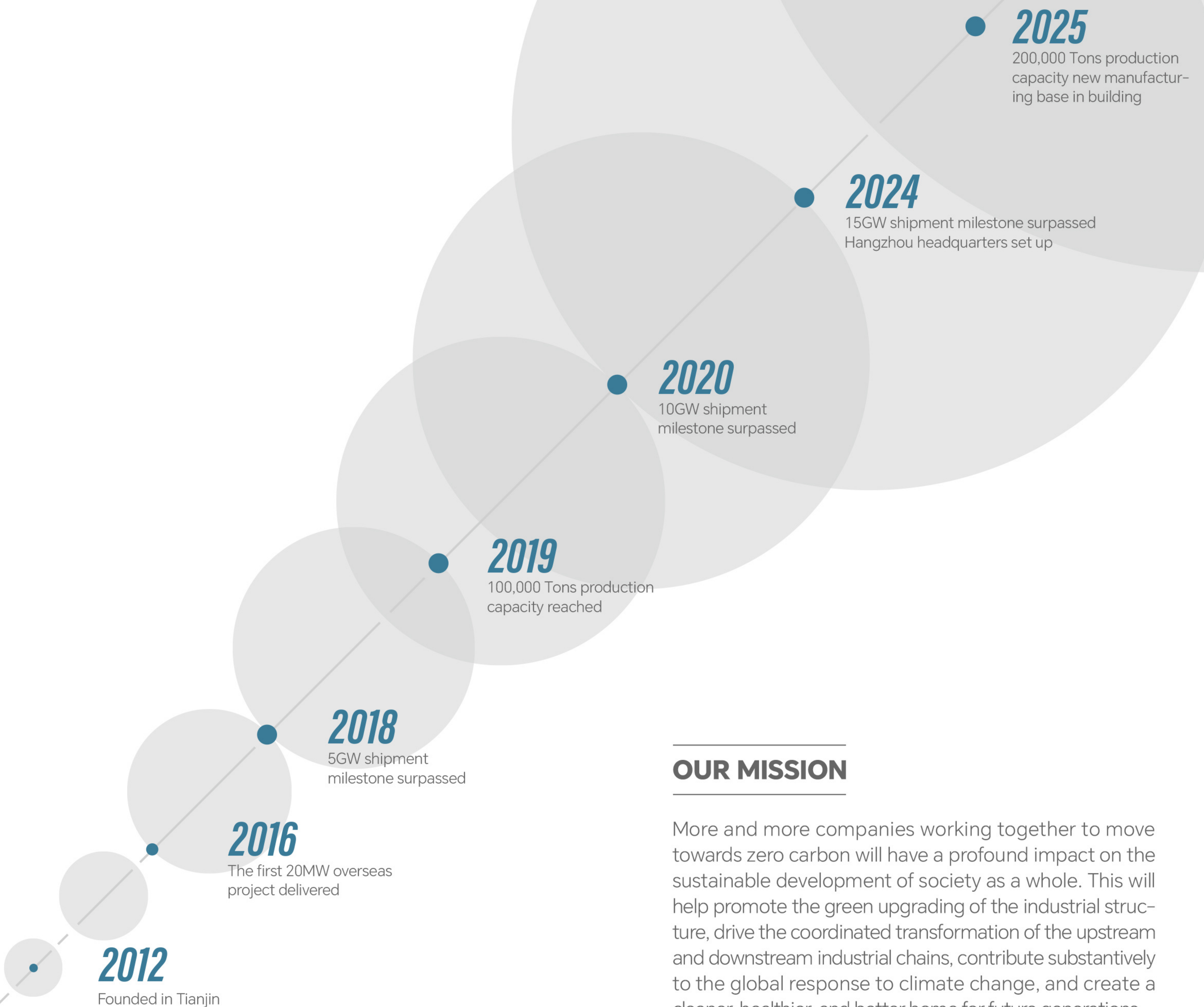

OUR MISSION

More and more companies working together to move towards zero carbon will have a profound impact on the sustainable development of society as a whole. This will help promote the green upgrading of the industrial structure, drive the coordinated transformation of the upstream and downstream industrial chains, contribute substantively to the global response to climate change, and create a cleaner, healthier, and better home for future generations.



11

Global layout

China, Singapore, Japan, Malaysia, Philippines, Thailand, Vietnam, France, Spain, Italy, Ukraine

GLOBAL PRESENCE

*To leave a green world
To future generations.*

GLOBAL PRESENCE



PRODUCTS

Taking sustainable development as our mission, we promote the ecological balance of the earth, and guard the natural home on which we depend through the deep integration of innovative technology and green practices.



Zenith-NEO

Single-Row Single-Point Driven

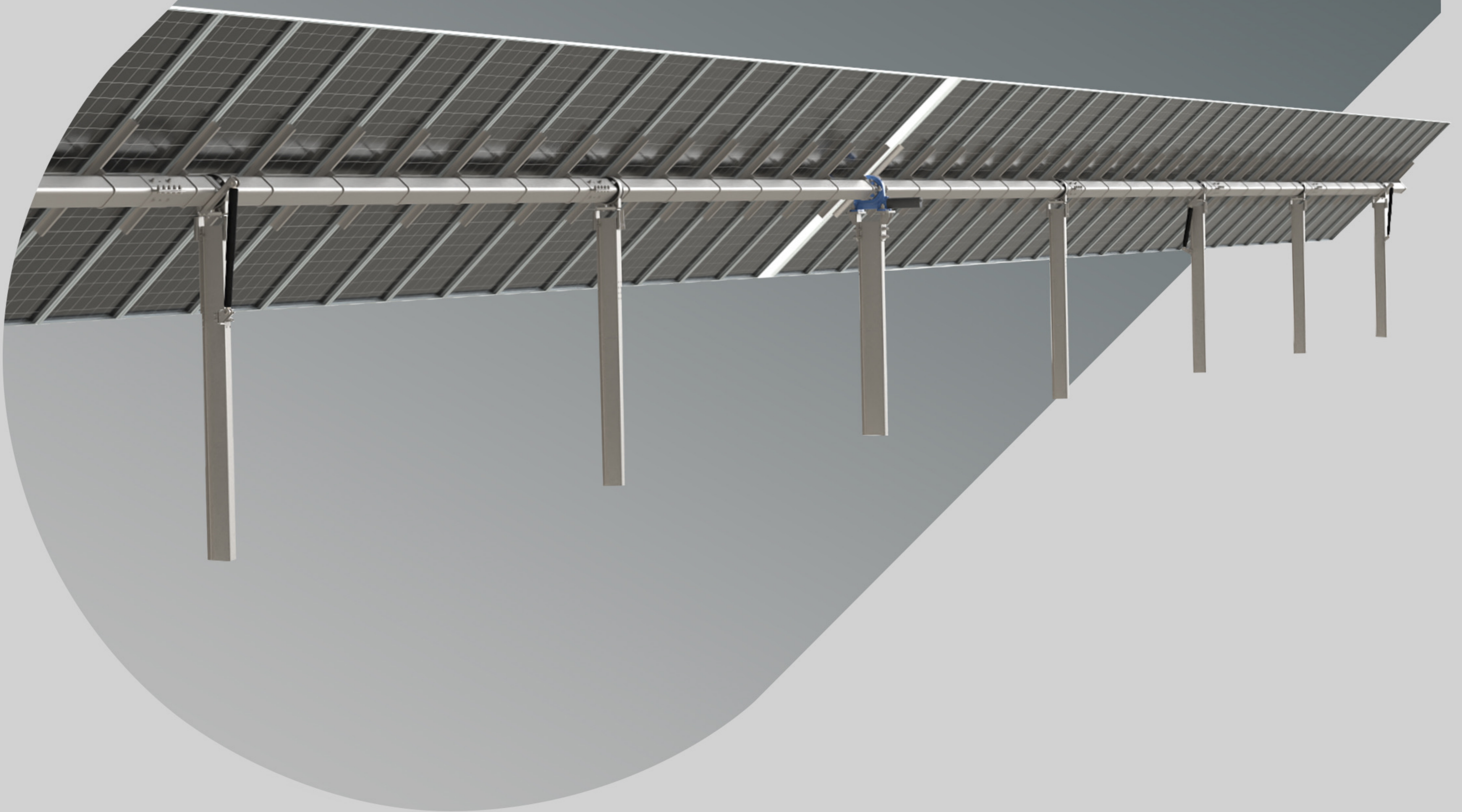

TERRAIN FOLLOWING

Adapts to up to 20% north-south slope, reducing site grading and civil works costs. Ideal for mountains, hills, agrivoltaics, and irregular terrain, enabling more flexible plant layout.

EASY-INSTALLATION

Standardized modular design with optimized critical connection points enables efficient installation and rapid assembly. Shortens construction time, reduces installation difficulty, and improves project delivery efficiency.

SOLID RELIABLE

Enhanced wind resistance and overall stability through aerodynamic and structural optimization, combined with high-strength materials. Delivers steady performance under complex environments and various operating conditions, ensuring station reliability.

HIGH-COMPATIBILITY

Compatible with mainstream 182 mm / 210 mm large-format, high-power PV modules, and adaptable to multiple foundation types. Meets application needs across different terrains, geological conditions, and project requirements, offering more flexible system configuration.

● Structural Parameters

System Type	Single-row Single-axis Tracking System
Tracking Angle	±60°
Drive Mechanism	Rotary drive
Number of Single-Row Modules	Up to 90 modules
Module Type	Compatible with all modules
Terrain Adaptability	N-S slope 20% Max. , E-W unrestricted
Pile Foundation Type	Ramming pile/Concrete pile/PHC
Structural Material	HDG/ZAM/Pre-HDG
System Voltage	300VDC ~ 1500VDC
Operating Ambient Temperature	-30°C ~ +60°C
Wind Resistance Design	Up to 60m/s

● Control Parameters

Tracking Method	Astronomical Algorithm + Closed-Loop Control
Tracking Accuracy	≤2°
Communication Method	Zigbee Wireless / RS485 Wired
Power Supply Method	String Power Extraction / AC Power Supply
Daily System Power Consumption	Approx. 0.05kWh/day
Protection Rating	IP65
Anti-Shadow Tracking	Yes
Night Return Mode	Yes
High Wind Protection Mode	Safety angle adjustable
Heavy Snow Mode	Optional
Flood Mode	Optional

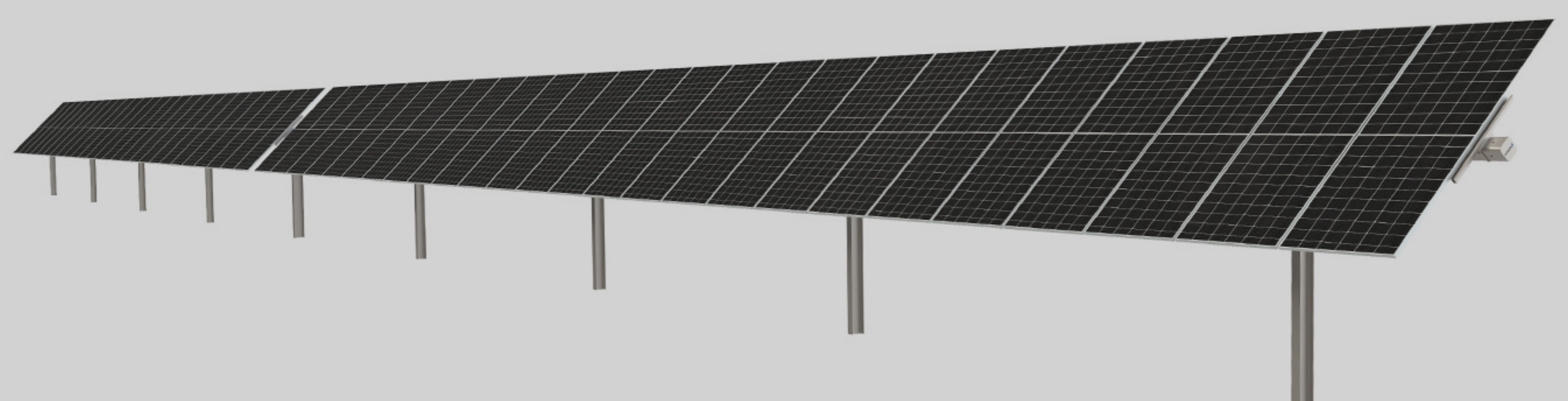

Zenith-MAX

Single-Row Multi-Point Driven

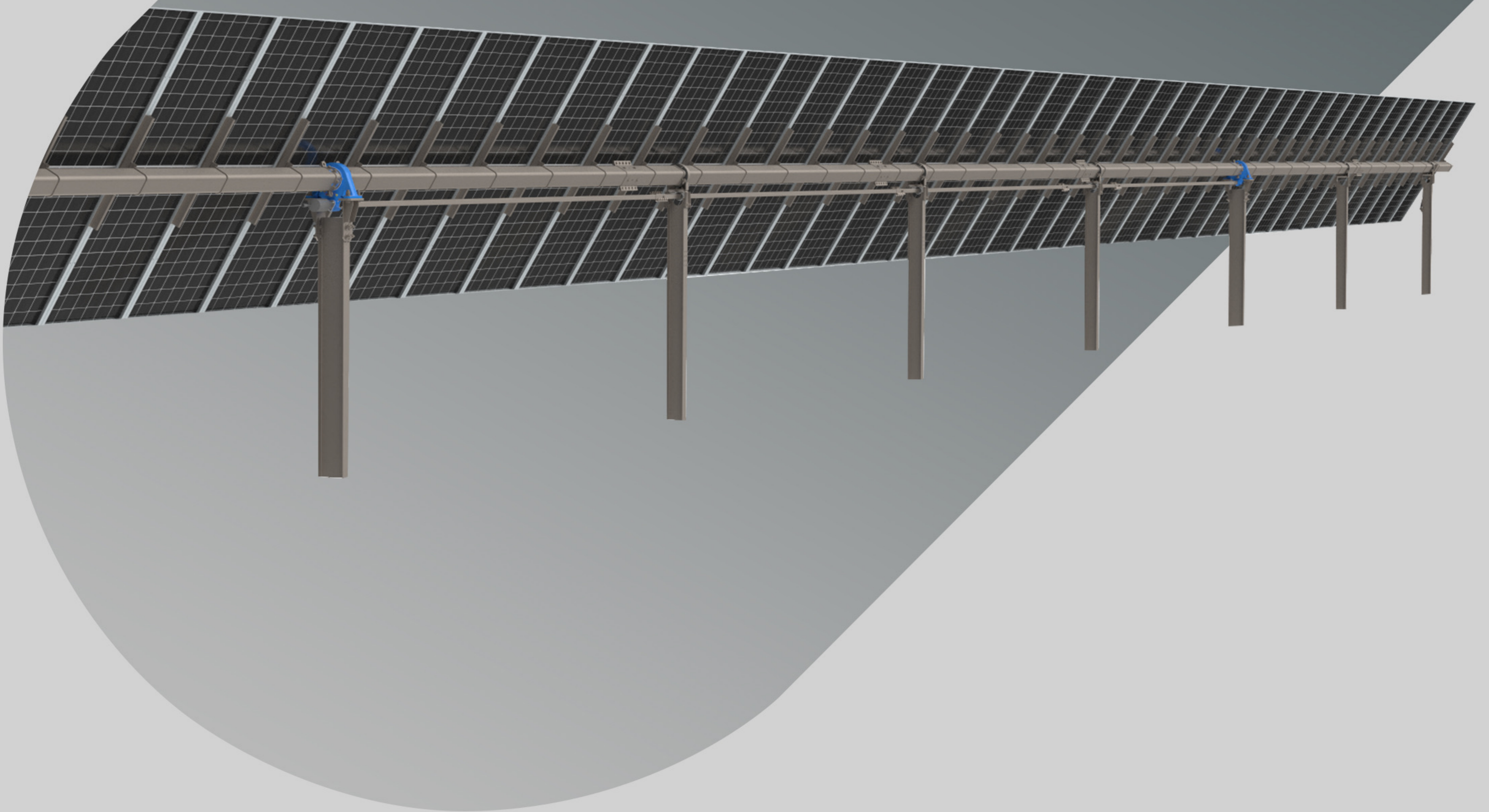

MULTI-DIMENSIONAL

Features a multi-dimensional modular design with flexible structural adjustment, enabling excellent compatibility with undulating mountainous terrain, irregular land parcels, and differential settlement conditions. Improves suitability for complex sites while reducing the need for site grading and simplifying foundation construction.

HIGH YIELD

Powered by an intelligent tracking algorithm that combines astronomical tracking with terrain-adaptive backtracking to reduce inter-row shading losses. Further improves power generation performance in complex terrain and helps maximize the plant's lifecycle returns.

ROBUST STRUCTURE

Coordinated multi-point drive mechanics enhance overall torsional rigidity and wind stability. Under challenging conditions such as strong winds, the system effectively suppresses wind-induced vibration, reduces the risk of instability, and improves safety and reliability.

EASY-INSTALLATION

Standardized modular design with optimized critical connection points enables efficient installation and rapid assembly. Shortens construction time, reduces installation complexity, and improves project delivery efficiency.

● Structural Parameters

System Type	Single-row Single-axis Tracking System
Tracking Angle	$\pm 60^\circ$
Drive Mechanism	Rotary drive, multi-point parallel drive
Number of Single-Row Modules	Up to 120 modules
Module Type	Compatible with all modules
Terrain Adaptability	N-S slope 20% Max. , E-W unrestricted
Pile Foundation Type	Ramming pile/Concrete pile/PHC
Structural Material	HDG/ZAM
System Voltage	300VDC ~ 1500VDC
Operating Ambient Temperature	$-30^\circ\text{C} \sim +60^\circ\text{C}$
Wind Resistance Design	Up to 60m/s

● Control Parameters

Tracking Method	Astronomical Algorithm + Closed-Loop Control
Tracking Accuracy	$\leq 2^\circ$
Communication Method	Zigbee Wireless / RS485 Wired
Power Supply Method	String Power Extraction / AC Power Supply
Daily System Power Consumption	Approx. 0.05kWh/day
Protection Rating	IP65
Anti-Shadow Tracking	Yes
Night Return Mode	Yes
High Wind Protection Mode	Flat Protection
Heavy Snow Mode	Optional
Flood Mode	Optional

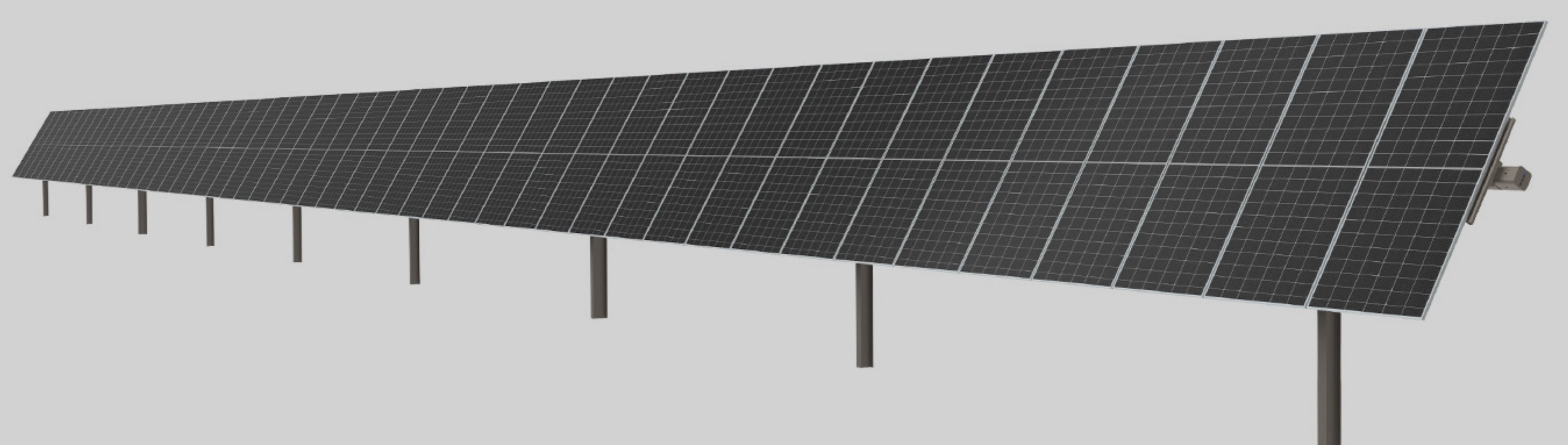

Zenith-SYN

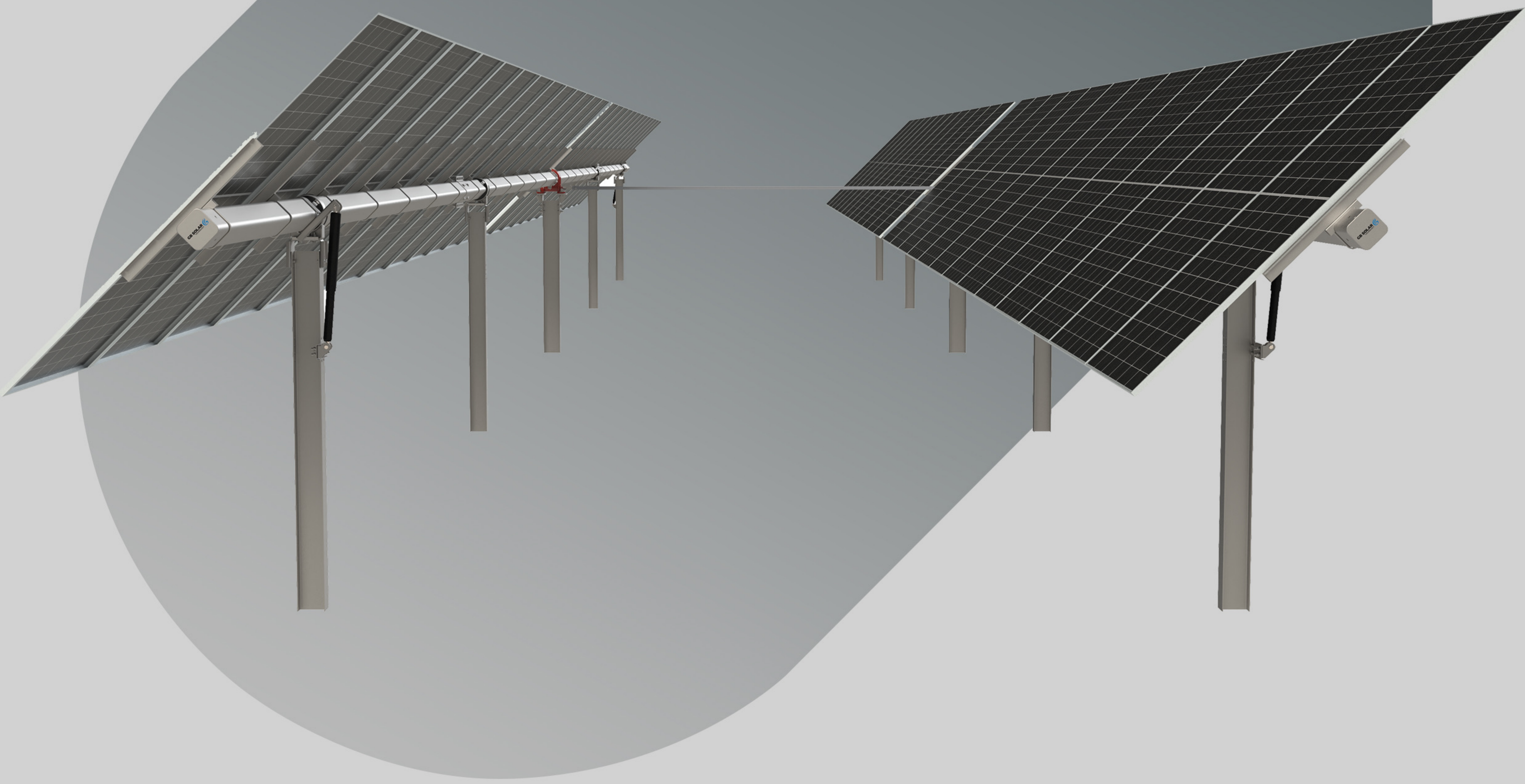
Dual-Row
Intelligent Linked**SYNCHRONICITY**

A dual-row shared-drive structure combined with a drive-shaft mechanical linkage enables synchronized and coordinated tracking of two rows. This improves transmission consistency and operational smoothness, and helps reduce overall BOS costs.

ADAPTABILITY

A cardan joint transmission structure flexibly accommodates terrain undulations in both north-south and east-west directions, supporting installation on slopes up to 15%. Improves installation adaptability and site compatibility to meet project needs in complex terrain.

DEPENDABILITY

Mechanical transmission with a self-locking design enhances overall rigidity and torsional resistance. Maintains structural stability under challenging conditions such as strong winds, ensuring system safety and long-term reliability.

SMART O&M

Mobile app-based intelligent commissioning and convenient management enable faster parameter setup, clearer status monitoring, and more efficient on-site maintenance. Improves commissioning efficiency and O&M response speed, optimizing the overall O&M experience.

● Structural Parameters

System Type	Double-row linked single-axis tracking system
Tracking Angle	$\pm 60^\circ$
Drive Mechanism	Rotary Drive
Number of Single-Row Modules	Up to 90 modules
Module Type	Compatible with all modules
Terrain Adaptability	N-S slope 20% Max. , E-W unrestricted
Pile Foundation Type	Ramming pile/Concrete pile/PHC
Structural Material	HDG/ZAM/Pre-galvanized
System Voltage	300VDC ~ 1500VDC
Operating Ambient Temperature	$-30^\circ\text{C} \sim +60^\circ\text{C}$
Wind Resistance Design	Up to 60m/s

● Control Parameters

Tracking Method	Astronomical Algorithm + Closed-Loop Control
Tracking Accuracy	$\leq 2^\circ$
Communication Method	Zigbee Wireless / RS485 Wired
Power Supply Method	String Power Extraction / AC Power Supply
Daily System Power Consumption	Approx 0.05kWh/Day
Protection Rating	IP65
Anti-Shadow Tracking	Yes
Night Return Mode	Yes
High Wind Protection Mode	Protection angle is adjustable.
Heavy Snow Mode	Optional
Flood Mode	Optional

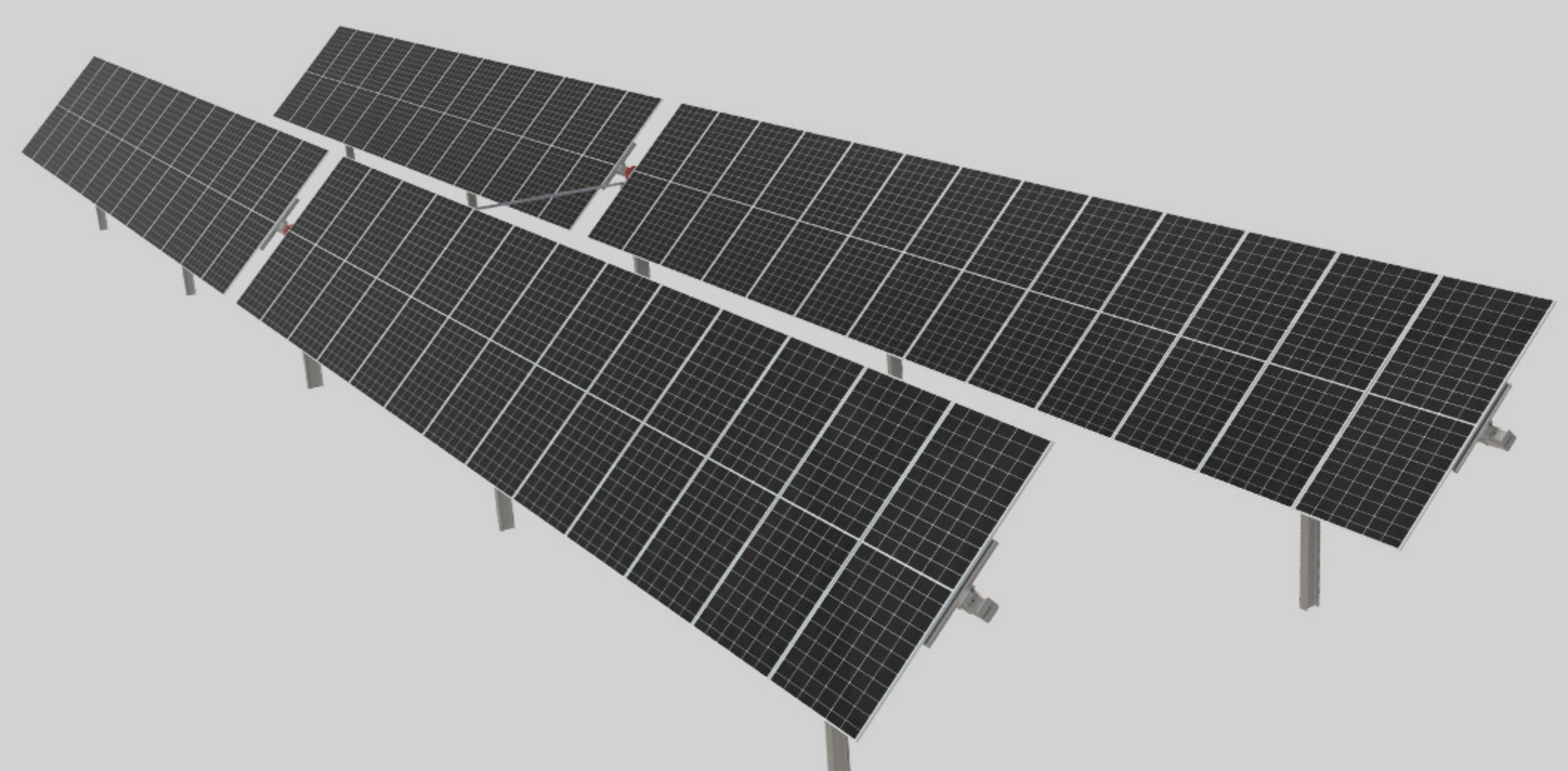



ALL TERRAIN MOUNTING SYSTEM

MAIN STRUCTURE MATERIAL

HDG/ZAM

ACCESSORIES MATERIAL

Aluminum and Stainless steel

FOUNDATION ADAPTION

PHC/Ground screw/
Driven pile/Cast-in-place

WARRANTY

10 Yr Warranty, 25 Yr Life-span

MODULE TILT RANGE

0~60

GROUND CLEARANCE

0.3~3m

N-S PIER SPACING

Up to 5m

E-W PIER SPACING

Up to 3m

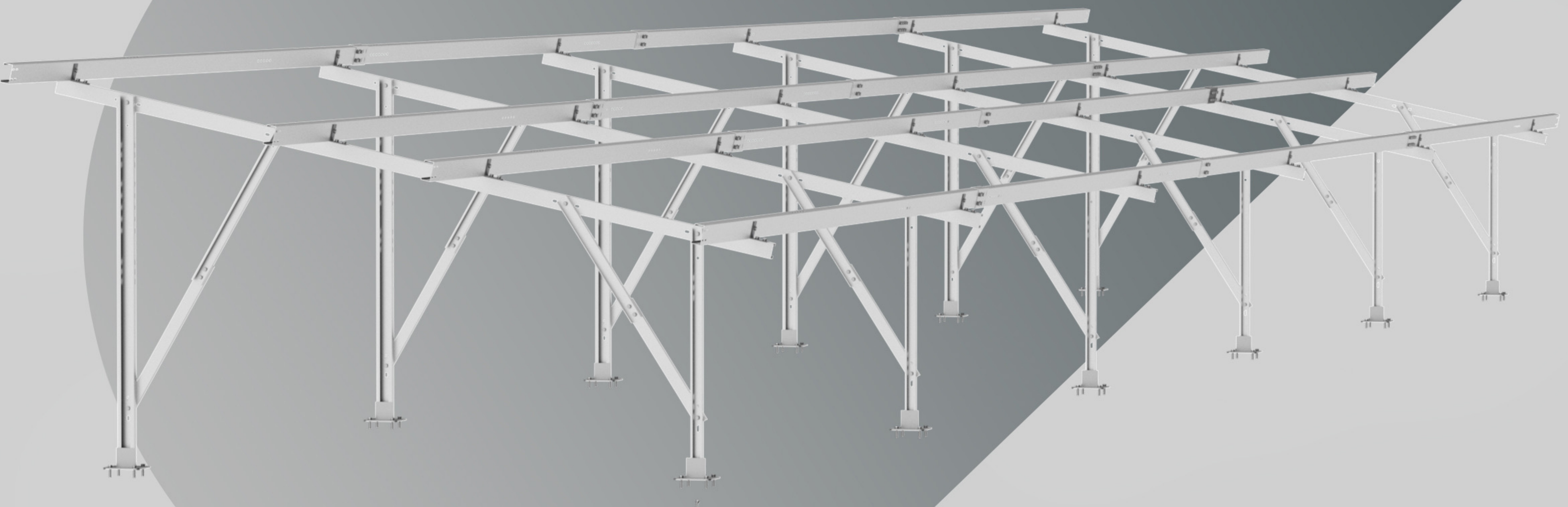

COST-EFFECTIVE

Our professional engineering team can provide customized designs based on design standards with minimized steel used, to lower the cost from not only material cost but also transportation, installation manpower, and more.

EXTREME ENVIRONMENTS

Meet a variety of extreme meteorological conditions design, such as gale or heavy snow, high corrosion, and others. A variety of special terrain designs, such as sand, mountain, wetland, beach, and others. The design team will suggest the most adaptation solutions.

EASY-INSTALLATION

Simplified design of the main structural components, significantly reducing the number of components and no on-site drilling or welding. Under regular conditions, only takes 10 mins to install 1 kWp, and no heavy machinery required.

KEY FEATURES

- # Rugged construction
- # CE certified
- # Flexible architecture
- # 25-year life-span

Spain
20MW



France
50MW



Vietnam
50MW



PROJECT EXAMPLES

ROOFTOP MOUNTING SYSTEM

ALUMINUM SOLUTION

WATER DRAINAGE SYSTEM

Optional

ROOF TYPE ADAPTION

Color steel roof / tile roof /
Concrete roof

CE CERTIFICATE

CE 认证

WARRANTY

10 Yr Warranty, 25 Yr Life-span

ROOF PITCH

0~60

MAIN STRUCTURE MATERIAL

6005-T5 / 6063-T6

ACCESSORIES MATERIAL

Aluminum and
Stainless steel

ROOF FIXING SOLUTION

Self-tapping screw with
Waterproof solution /
Customized clamp or hook

STEEL SOLUTION

WATER DRAINAGE SYSTEM

Optional

ROOF TYPE ADAPTION

Color steel roof / tile roof /
Concrete roof

CE CERTIFICATE

CE 认证

WARRANTY

10 Yr Warranty, 25 Yr Life-span

ROOF PITCH

0~60

MAIN STRUCTURE MATERIAL

HDG / ZAM

ACCESSORIES MATERIAL

Aluminum and
Stainless steel

ROOF FIXING SOLUTION

Ballast block / Embedded bolt /
Chemical bolt



LIGHT WEIGHT

Under regular condition, the mounting system only weight 1 kg for every square meter (with aluminum solution), almost have no effect on roof bearing.

EASY INSTALLATION

Simplified design of the main structural components, significantly reducing the number of components and no on-site drilling or welding. Only takes 5 mins to install 1 kWp and no heavy machinery required.

ADAPTABILITY

Capable of meeting installation needs for various roof structures, designed to meet various types of special needs, for instance waterproofing, loading, lighting and others.

KEY FEATURES

- # Rugged construction
- # CE certified
- # Flexible architecture
- # 25-year life-span

Portugal
3.72MW



Vietnam
3MW



Singapore
1.55MW



INTEGRATED CARPORT

MAIN STRUCTURE MATERIAL

HDG/ZAM

ACCESSORIES MATERIAL

Aluminum and Stainless steel

ARRAY ARRANGEMENT

Single row mono-pitch/
Double row mono-pitch/
Double row duo-pitch

WARRANTY

10 Yr Warranty, 25 Yr Life-span

MODULE TILT RANGE

0~60

GROUND CLEARANCE

From 2.2m

PIER SPACING

2.5m ~ 7.5m

COLUMN FORM

π - frame / Y - frame
T - frame / V - frame

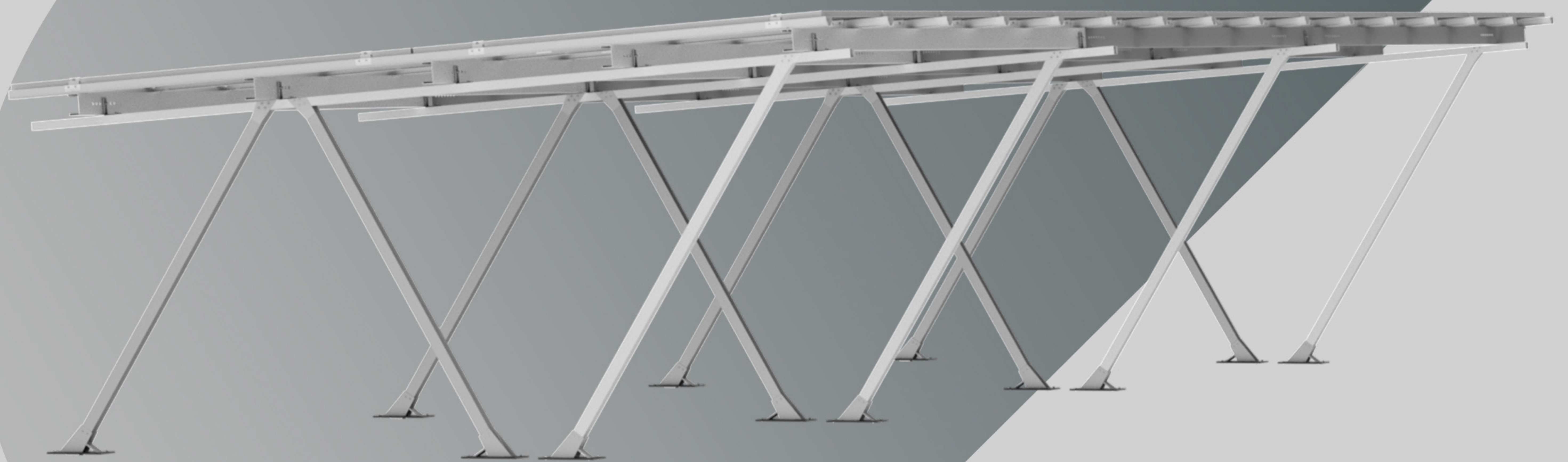

SPACE UTILIZATION

Carport systems combine minimum ground footprint with lightweight construction and a framework that allows unhindered opening of car doors. Vertical posts are positioned up to 7.5m apart with a typical 3-bay span.

ADDITIONAL OPTIONS

- # Powder coat finish
- # Cable management
- # Guttering management
- # Energy storage and EV charging

APPLICATION SCENARIOS

The perfect combination of photovoltaic power generation and carport is one of the applications of BIPV photovoltaic building integration. Through different column design forms, we provide a carport design appearance that adapts to various scenarios.

KEY FEATURES

- # Rugged construction
- # Flexible architecture
- # CE certified
- # 25-year life-span

Algeria
5.63MW



Bahrain
1.17MW



Italy
1.88MW



PROFILE STEEL PRODUCTION

SECTION TYPE	APPLICABLE STANDARD	SIZE RANGE	THICKNESS RANGE
CHS	EN 10219-2:2006	φ 21.3 ~ 76.3mm	2.0 ~ 5.0 mm
SHS	EN 10219-2:2006	□ 40~160 mm	2.0 ~ 16.0 mm
IPE	EN 10025-2:2004	H 80x46 ~ H 300x150	3.8/5.2 ~ 7.1/10.7 mm
L	EN 10056	L 25 ~ 80mm	3.0 ~ 12.0 mm
LNP	EN 10056	L 50x30 ~ L 100x75	4.0 ~ 11.0 mm
C-type		C 40 ~ 160 mm	1.5 ~ 3.0 mm
U-type		U 41x21 ~ 41x72 mm	1.6 ~ 2.5 mm

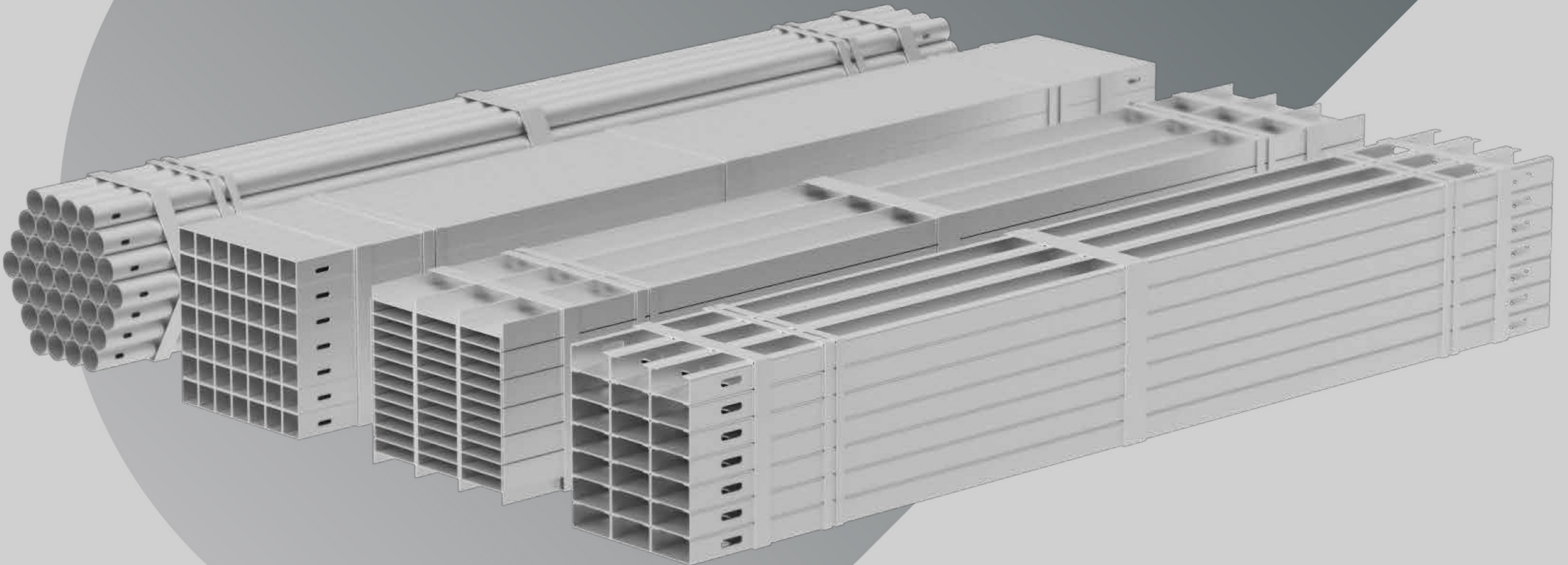

PRODUCTION CAPACITY

Annual production capacity reaches 100,000 tons. Equipped with over 20 full-automatic production lines, advanced laser cutting machine and screw pile production lines.

DELIVERY CAPACITY

With full production capacity, after PO signed, 1500 tons delivers at the first 15 days, and 3000 tons in every 10 days.

QUALITY CONTROL

We have formed a strictness closed loop of quality control system, from raw material incoming inspection, product inspection, galvanizing examine, to packing and transportation, till the products in your hands.

RAW MATERIAL

Cooperate with well-known international steel manufacturers, we can provide all kinds of raw materials to meet EU, ASTM and GB standards, also have full set of quality inspection report and warranty.

EN 10219-2:2006

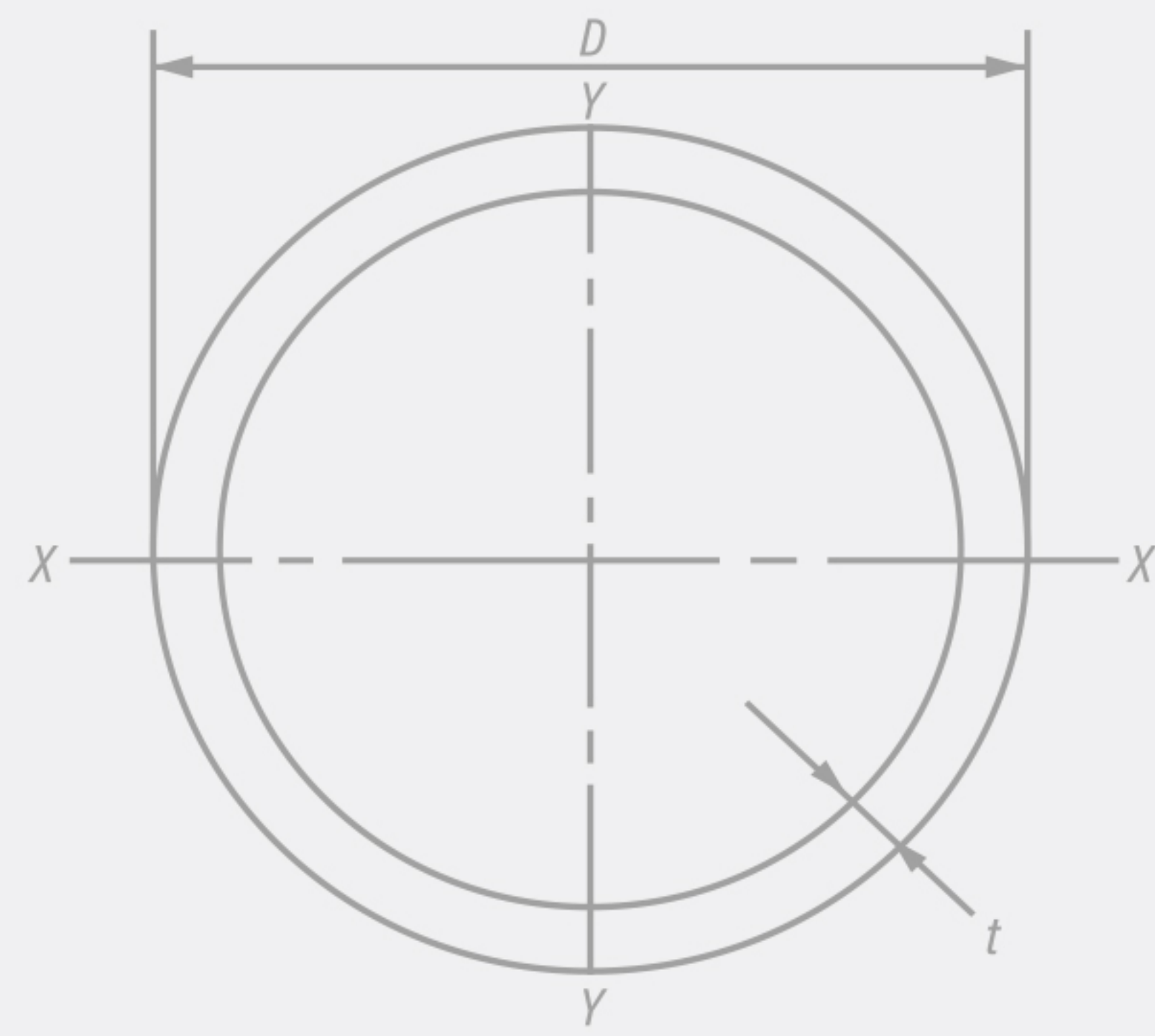

CHS	Diameter(mm) D	Thickness(mm) t
21.3	21.3	1.5 ~ 4.0
26.9	26.9	1.5 ~ 5.0
33.7	33.7	2.0 ~ 5.0
42.4	42.4	2.5 ~ 5.0
48.3	48.3	3.0 ~ 6.0
60.3	60.3	4.0 ~ 6.0
76.1	76.1	4.0 ~ 6.0

EN 10219-2:2006

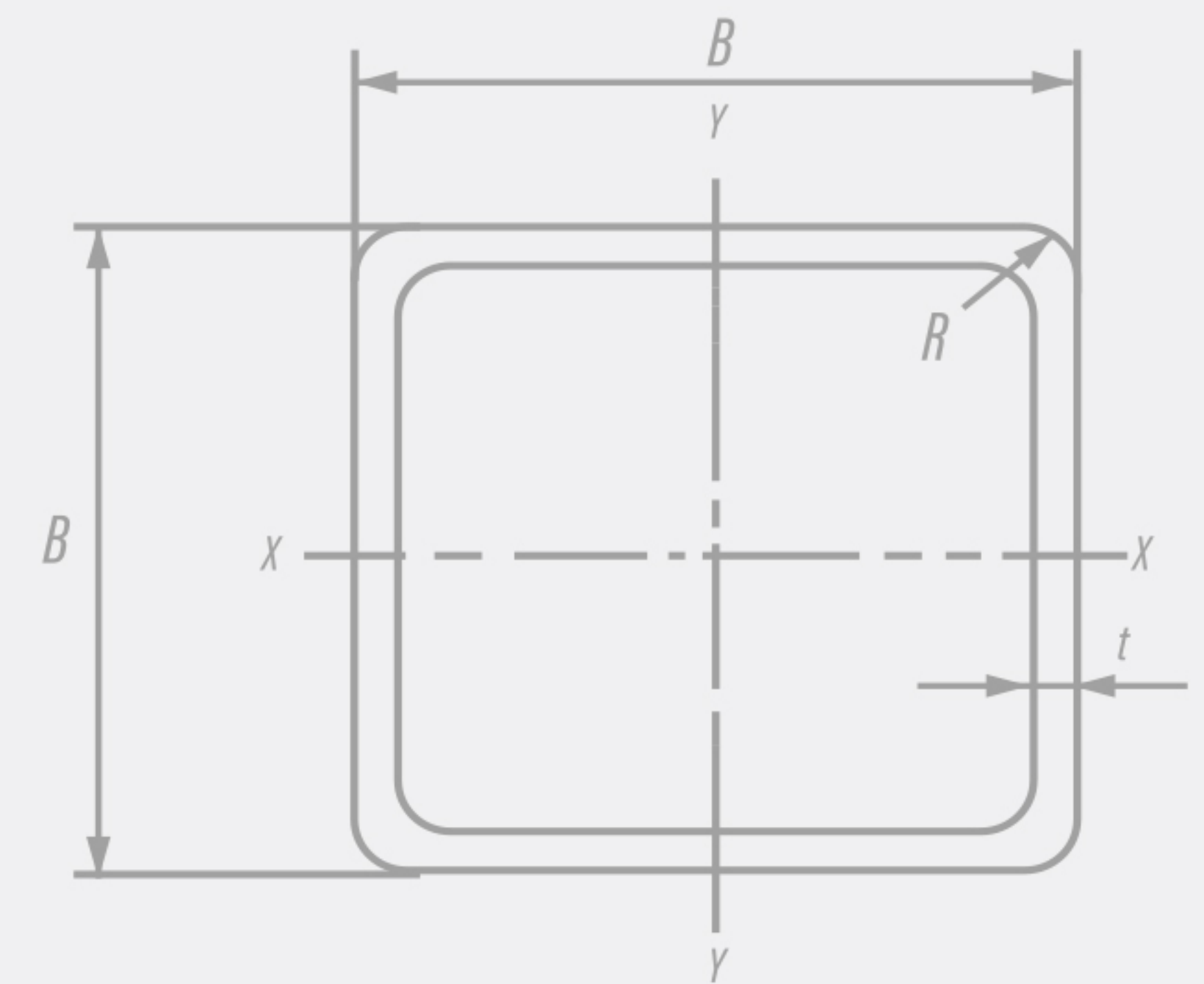

F	Height(mm) B	Thickness(mm) t
70	70	2.5 ~ 5.0
80	80	2.5 ~ 5.0
90	90	3.0 ~ 6.0
100	100	4.0 ~ 6.0
110	110	4.0 ~ 6.0
120	120	4.0 ~ 8.0
130	130	4.0 ~ 8.0

EN 10025-2:2004

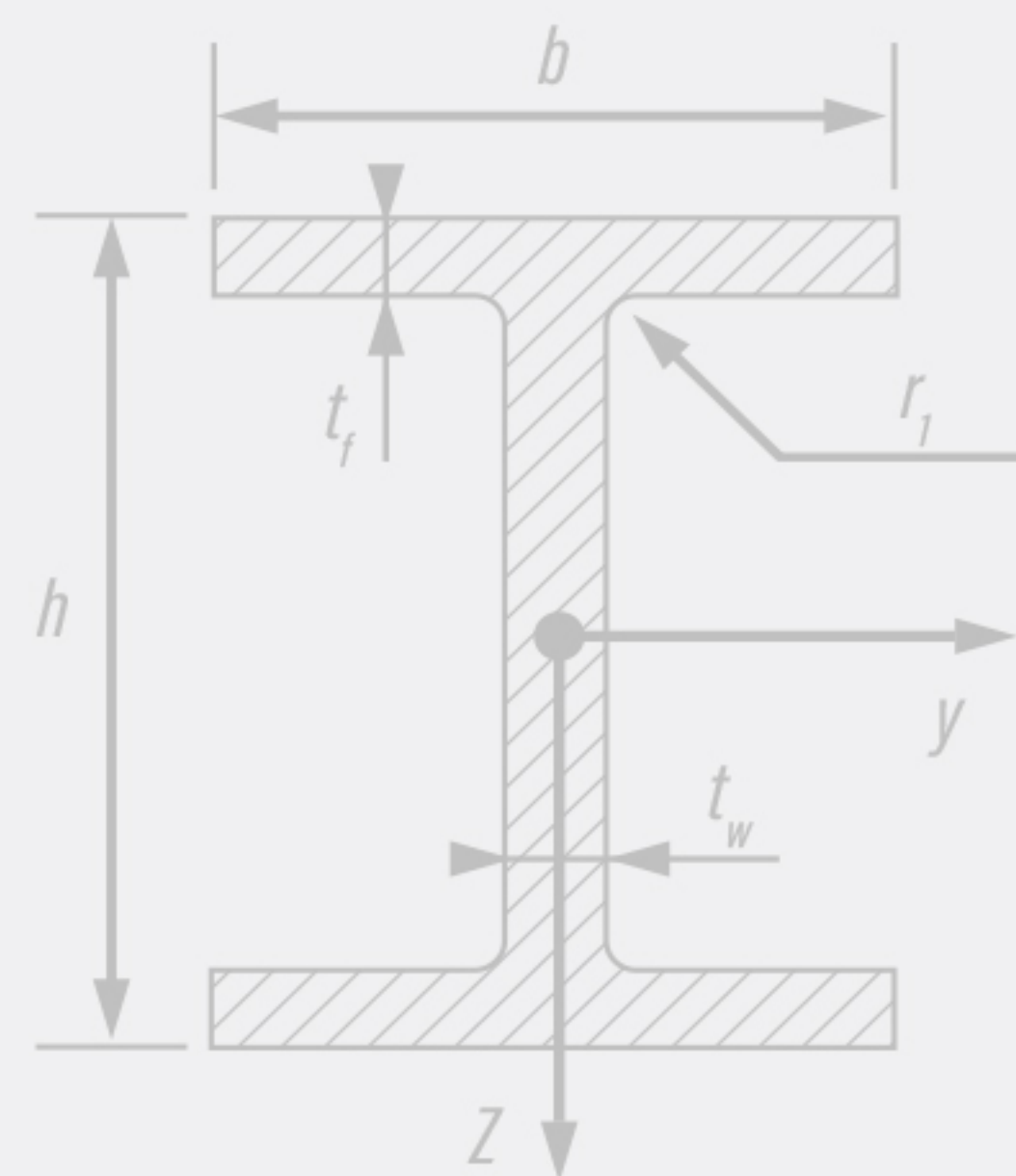

IPE	Height (mm) h	Width (mm) b	Thickness (mm) t_w	Thickness (mm) t_f
80	80	46	3.8	5.2
100	100	55	4.1	5.7
120	120	64	4.4	6.3
140	140	73	4.7	6.9
160	160	82	5	7.4
180	180	91	5.3	8
200	200	100	5.6	8.5

EN 10056

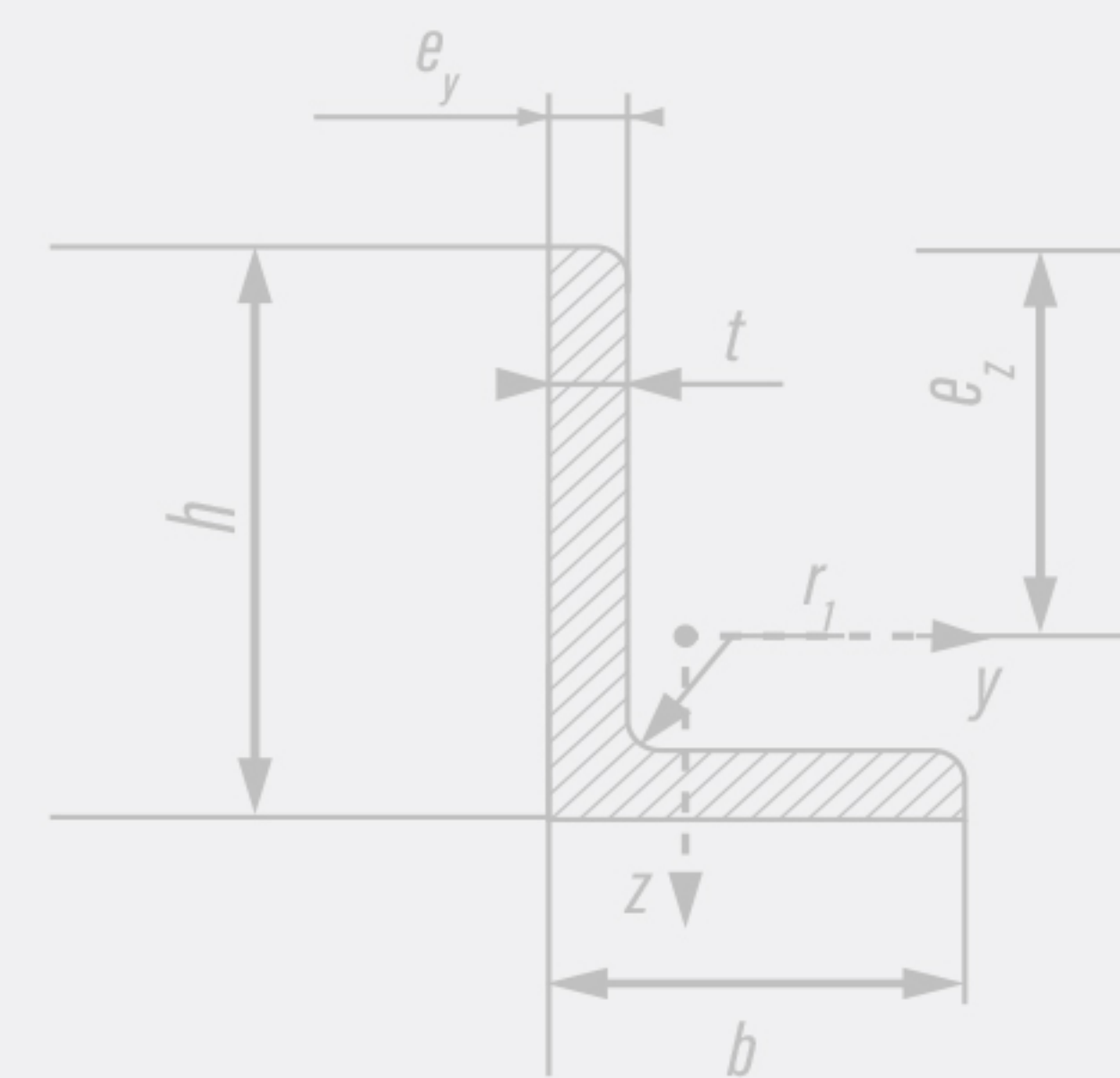

LNP	Height(mm) h	Width(mm) b	Thickness(mm) t
LNP50x30	50	30	4.0 ~ 5.0
LNP60x40	60	40	5.0 ~ 7.0
LNP75x50	75	50	6.0 ~ 7.0
LNP80x40	80	40	6.0 ~ 8.0
LNP90x60	90	60	6.0 ~ 8.0
LNP100x50	100	50	6.0 ~ 10.0
LNP100x65	100	65	7.0 ~ 11.0

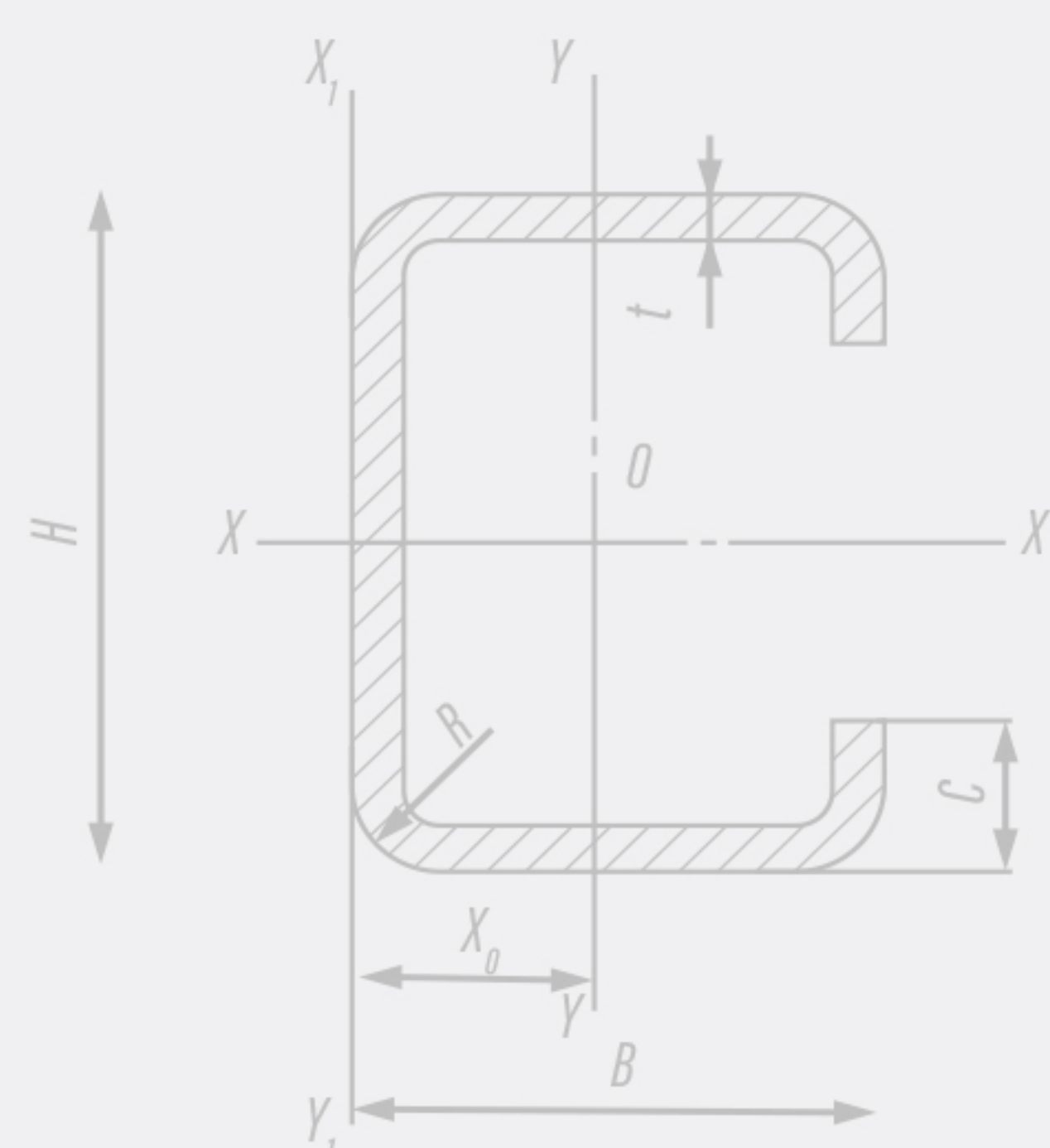

C	Height(mm) H	Width(mm) B	Thickness(mm) t
50	150	20-50	1.5 ~ 2.75
60	150	20-60	1.5 ~ 2.75
70	150	20-60	1.5 ~ 2.75
80	175	20-60	1.5 ~ 2.75
90	175	20-60	1.5 ~ 2.75
100	200	20-60	1.5 ~ 2.75
110	200	20-60	1.5 ~ 2.75
120	200	20-60	1.5 ~ 2.75

GENERATE EACH AND EVERY BIT OF CLEAN ELECTRICITY SHINES
WITH THE LIGHT OF TECHNOLOGY AND QUALITY

E-MAIL: info@gsolartech.com
ADDRESS: ROOM 13A05 JOYWARE BUILDING,
HANGZHOU CITY, ZHEJIANG PROVINCE, CHINA